

Surname	Centre Number	Candidate Number
First name(s)		2



GCE AS

B400U10-1



O21-B400U10-1



MONDAY, 11 OCTOBER 2021 – MORNING

BIOLOGY – AS component 1
Basic Biochemistry and Cell Organisation

1 hour 30 minutes

For Examiner's use only		
Question	Maximum Mark	Mark Awarded
1.	12	
2.	16	
3.	9	
4.	13	
5.	16	
6.	9	
Total	75	

ADDITIONAL MATERIALS

In addition to this paper you will require a calculator and a ruler.

INSTRUCTIONS TO CANDIDATES

Use black ink or black ball-point pen. Do not use gel pen or correction fluid.

You may use a pencil for graphs and diagrams only.

Write your name, centre number and candidate number in the spaces at the top of this page.

Answer **all** questions.

Write your answers in the spaces provided in this booklet. If you run out of space, use the additional page at the back of the booklet, taking care to number the question(s) correctly.

INFORMATION FOR CANDIDATES

The number of marks is given in brackets at the end of each question or part-question.

The assessment of quality of extended response (QER) will take place in question **6**.

The quality of written communication will affect the awarding of marks.



OCT21B400U10101

Answer all questions.

1. Water provides an ideal environment for many living organisms due to its unique properties. It is involved in many of the processes that maintain life.

(a) (i) Explain why water is described as a polar molecule. [2]

.....

.....

.....

.....

.....

(ii) Explain why water is described as a universal solvent. [2]

.....

.....

.....

.....

.....



Image 1.1 shows a typical pond.

Image 1.1

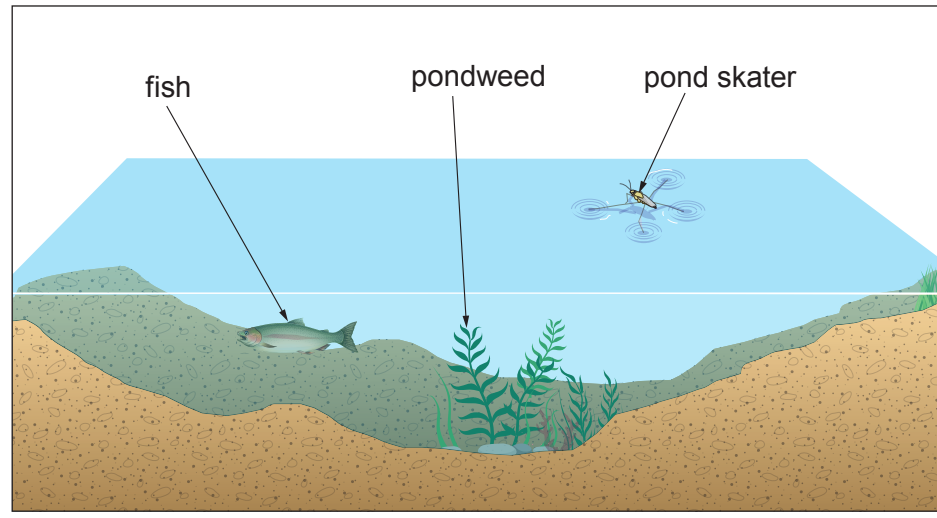

(b) With reference to **image 1.1**, use your knowledge of the **properties of water** to explain each of the following statements.

(i) The temperature of the pond stays relatively constant throughout the year. [2]

.....

.....

.....

(ii) Fish and plants can survive when the pond freezes over. [2]

.....

.....

.....

(iii) Pond skaters can live on the surface of the pond. [2]

.....

.....

.....

(iv) Pondweed can grow underwater. [2]

.....

.....

.....

B400U101
03



BLANK PAGE

**PLEASE DO NOT WRITE
ON THIS PAGE**



2. DNA molecules comprise two polynucleotide strands linked by hydrogen bonds between the base pairs. A short section of DNA is shown in **image 2.1**.

Image 2.1

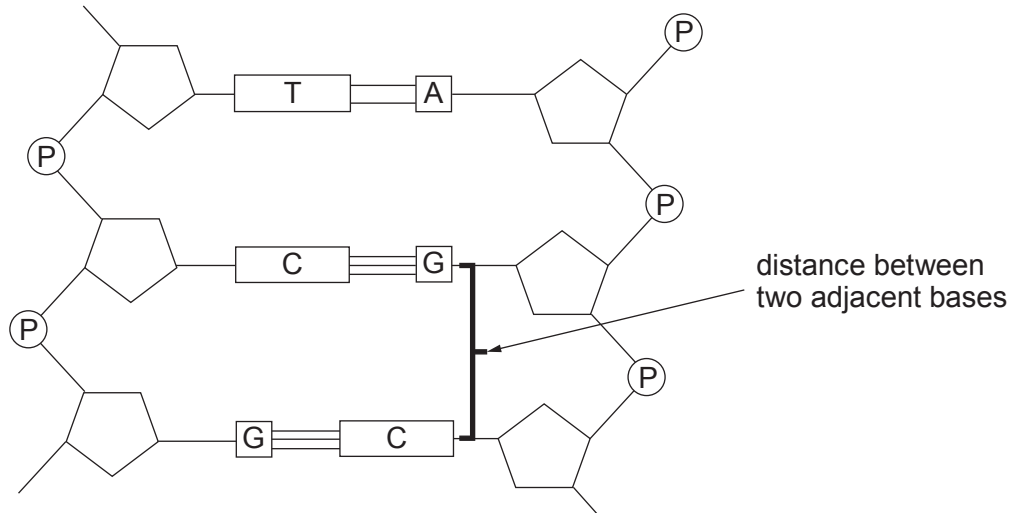

- (a) (i) **Draw a ring around one nucleotide.** [1]
- (ii) Each turn of the double helix contains 10 pairs of bases. A one metre length of DNA has 2.94×10^8 turns. Calculate the distance between two adjacent bases as shown in **image 2.1**. **Give your answer in nm.** [3]

Distance between base pairs = nm



Table 2.2 shows some mRNA base sequences together with their corresponding amino acids.

Examiner
only

Table 2.2

mRNA base sequence	Amino acid
UAG	stop codon
UUU	Phe
GAC	Asp
CUC	Leu
GUU	Val
AUG	Met
UAU	Tyr
ACC	Thr
CGU	Arg
GAU	Asp
ACA	Thr

- (b) (i) Using the data from **table 2.2** explain why the genetic code is described as degenerate. [1]

.....

- (ii) A section of bases in an mRNA molecule is shown in **table 2.3**. Use **table 2.2** to complete **table 2.3** to show:

- I. the base sequence of the DNA template from which the mRNA was transcribed; [1]
- II. the amino acid sequence coded for by this mRNA molecule. [1]

Table 2.3

DNA base sequence
mRNA base sequence	AUG	GUU	UAU	ACC	GAU	UAG
Amino acid sequence



Image 2.4 shows the process by which mRNA is used to synthesise a polypeptide.

Image 2.4

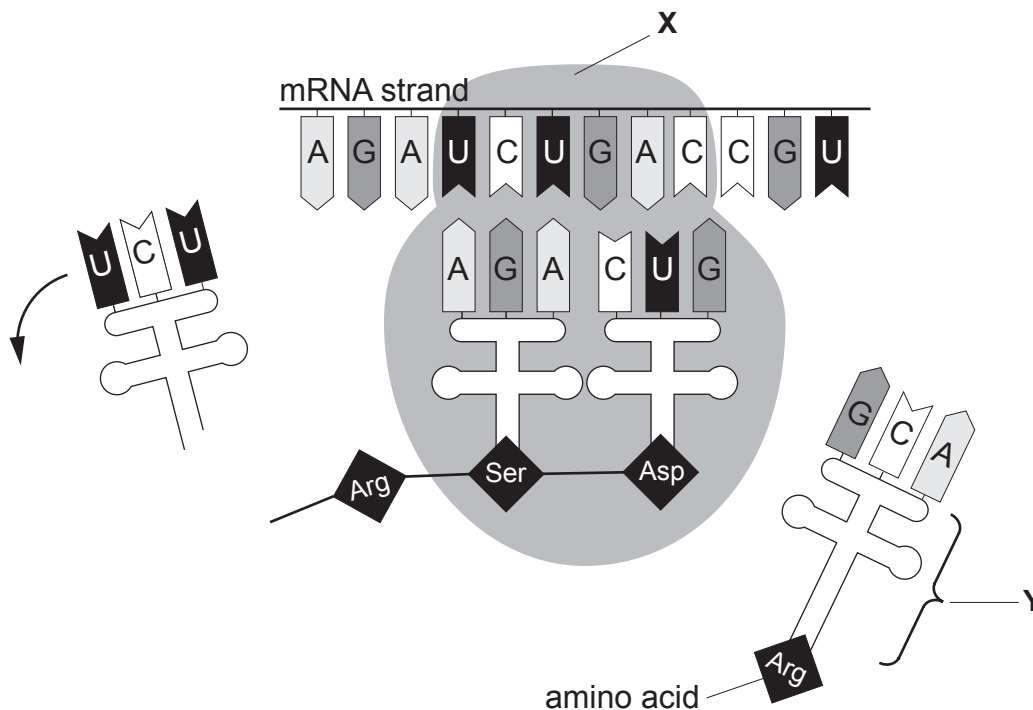

(c) (i) Name structures X and Y.

[2]

X

Y



Examiner
only

(ii) Name and describe the process shown in **image 2.4**.

[5]

.....

.....

.....

.....

.....

.....

.....

.....

.....

.....

.....

.....

.....

.....

B400U101
09

16



3. The main structural component of many bacterial cell walls is peptidoglycan. The molecular structure of peptidoglycan is illustrated in **image 3.1**. NAG and NAM are sugars that make up the polysaccharide chain component of peptidoglycan.

Image 3.1

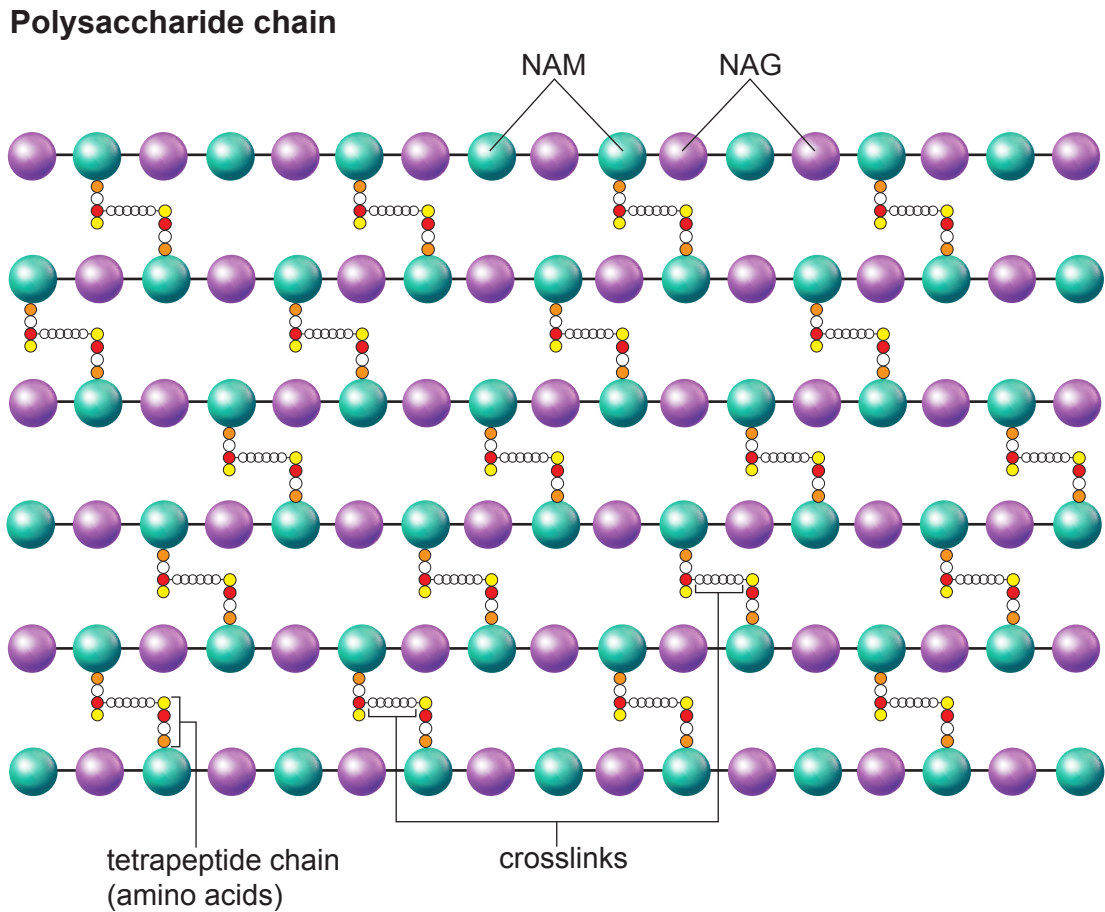

(a) Using **image 3.1** and your knowledge of plant cell wall structure, identify **four** differences in the structure of bacterial and plant cell walls. [4]

Bacterial cell wall	Plant cell wall
.....
.....
.....
.....

(b) Bacterial cells are hypertonic to their environments. Suggest how the structure of the bacterial cell wall enables bacteria to survive in such environments. [3]

.....

.....

.....

.....

.....

.....

Some antimicrobial agents kill bacteria by disrupting the formation of the cross-links between the amino acid chains in peptidoglycan.

(c) Suggest how the action of these anti-microbial agents could kill bacteria. [2]

.....

.....

.....

.....



Examiner only

4. **Image 4.1** shows an electron micrograph of part of an epithelial cell from the small intestine. **Image 4.2** shows a section through a capillary.

Image 4.1

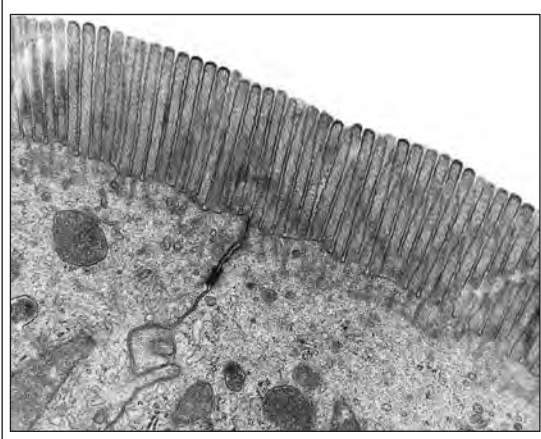
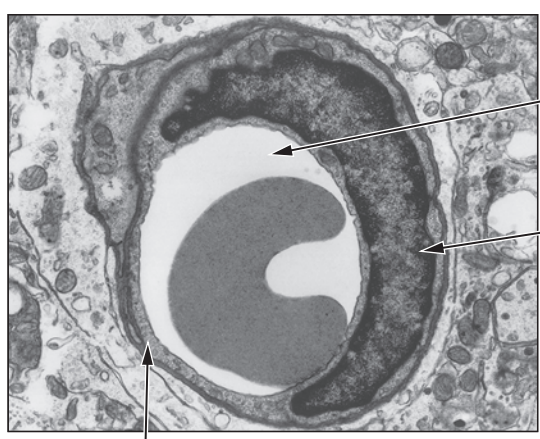

Image 4.2



lumen of capillary
nucleus of endothelial cell

capillary endothelial cell

(a) Fick's law of diffusion can be summarised as:

$$\text{Rate of diffusion} = \frac{\text{surface area} \times \text{difference in concentration}}{\text{length of the diffusion path}}$$

Using **images 4.1** and **4.2**, explain how the two cells are adapted to increase the rate of diffusion.

(i) Epithelial cell from small intestine. [1]

.....

.....

(ii) Capillary endothelial cell. [1]

.....

.....



- II. The movement of glucose from the cell to the bloodstream also requires a concentration gradient. Explain how this is maintained. [1]

.....

.....

- (c) Phlorizin is an inhibitor of glucose uptake by epithelial cells. The structures of glucose and phlorizin are shown in **image 4.4**.

Image 4.4

Glucose

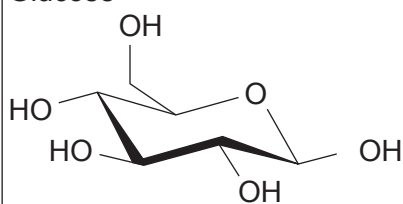

Phlorizin

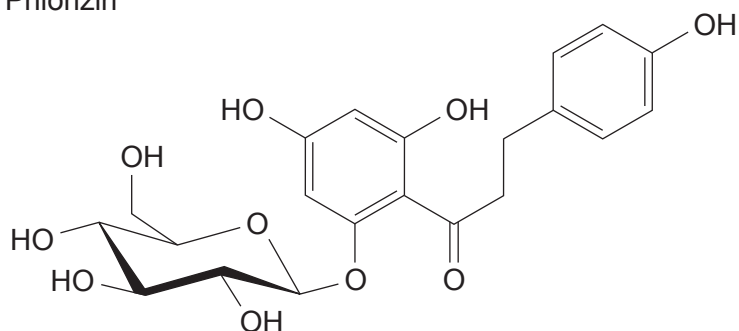

- (i) Suggest how phlorizin would affect the uptake of glucose in the small intestine by transport protein **P** in **image 4.3**. Explain your answer. [3]

.....

.....

.....

.....

.....

.....



Examiner
only

(ii) Most cells take in glucose for metabolism using glucose transport proteins like those in epithelial cells. Cancer cells have an extremely high requirement for glucose.

Some scientists have suggested that phlorizin could be used as a drug to treat cancer by blocking the cells' ability to take in glucose.

Using your knowledge of cancer cells, suggest why this treatment might reduce the growth of tumours. [2]

.....

.....

.....

.....

13



5. Lactose is a disaccharide found in milk. Some people are intolerant to lactose and would suffer stomach pain if they drank normal milk because they are unable to digest lactose.

(a) **Image 5.1** shows the structure of lactose.

Image 5.1

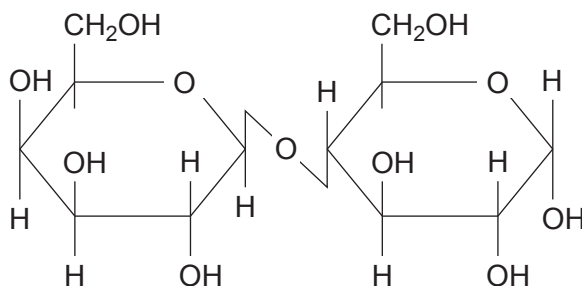

- (i) **Complete image 5.1** to show how the molecule would be broken down into two monosaccharides. [2]
- (ii) Name the bond which is broken in the digestion of lactose. [1]
-
- (iii) Explain why glucose and galactose are known as structural isomers of one another. [1]
-
-
-



Milk may be treated to break down the lactose into its constituent monosaccharides, glucose and galactose, by passing it down a column of the enzyme lactase immobilised in alginate beads.

Image 5.2 shows the experimental set-up used by a student to investigate the effect of changing bead diameter on the rate of hydrolysis of lactose.

Image 5.2

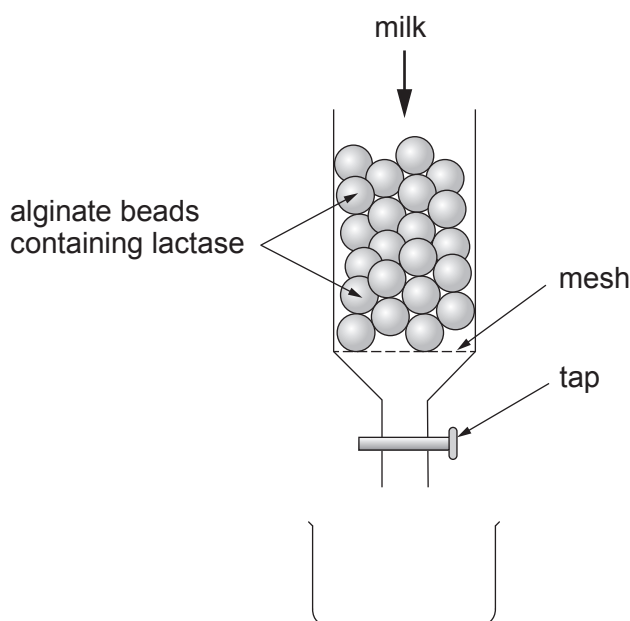

The following method was used to prepare the alginate beads.

- Mix 9.5 cm^3 of 2% sodium alginate solution and 0.5 cm^3 of lactase solution in a small beaker.
- Place 100 cm^3 1.5% calcium chloride solution into a clean beaker.
- Using a pipette with a 0.2 cm diameter, drop the alginate and lactase mixture into the calcium chloride to form beads.
- Remove the beads from the calcium chloride solution and rinse with distilled water.
- Repeat the method with pipettes of diameters 0.3, 0.4, and 0.5 cm.

The beads were then placed in a column as shown in **image 5.2** and the rate of lactose hydrolysis at room temperature for each diameter bead was measured.

- (b) (i) Suggest why it is important to rinse the beads with distilled water before use. [1]

.....

.....

.....



- (ii) Explain why the same solution of alginate and lactase was used to make all the different sizes of bead. [1]

.....

.....

- (iii) Carrying out the experiment at room temperature reduces reproducibility. Explain why and suggest how this could be improved. [2]

.....

.....

Table 5.3 shows the mean volume of the beads produced together with the number of beads of each diameter that can be made from 10 cm³ sodium alginate / enzyme mix.

Table 5.3

Diameter of bead / cm	Mean volume of one bead / cm ³	Number of beads made from 10 cm ³ sodium alginate / enzyme mix
0.2
0.3	0.014	710
0.4	0.034	290
0.5	0.065	150

- (c) (i) I. Calculate the mean volume of the 0.2 cm diameter beads.
 Volume of a sphere = $\frac{4}{3}\pi r^3$
 Where $\pi = 3.142$
Express your answer to 2 significant figures.
Write your answer in the table. [3]
- II. Calculate the number of these beads that could be made using the above method from 10 cm³ of the sodium alginate / enzyme mix.
Write your answer in the table. [2]



(ii) Predict the relationship between bead diameter and rate of hydrolysis.
Explain your answer.

[3]

Examiner
only

.....

.....

.....

.....

.....

.....

.....

16



Examiner
only

A large rectangular area containing 25 horizontal dotted lines for writing.



Examiner
only

A large rectangular area containing horizontal dotted lines for writing.



Examiner
only

.....

.....

.....

9

END OF PAPER



